



Innovent[®]
Air Handling Equipment

Innovating
to help people
feel good inside.

Creating

unique, custom HVAC solutions.

Since 1981, Innovent Air Handling Equipment has met the specialized needs of thousands of customers across North America, providing custom solutions for a wide range of facilities, including educational, health care, industrial, government, hospitality, recreational, research and retail.

Why custom instead of “off-the-shelf” products? Unique buildings and creative designers need flexible equipment offerings. With Innovent, system designers don’t need to compromise on energy efficiency, flexibility and longevity by using catalogued products. For new or replacement installations, let us design equipment to fit your exact needs, rather than change the building design to conform to limited product offerings.

Building upon our expertise in energy recovery and high-percentage outdoor air systems, Innovent’s broad portfolio also features high-performance custom air handling units, as well as dehumidification for special environments, such as operating rooms, ice rinks, and natatoriums.

Innovent, a business of Unison Comfort Technologies, is headquartered in Minneapolis and has multiple plants located throughout the United States. Carefully selected representatives in our distribution network are backed by expert factory support and training. Get to know a company that approaches your project with engineering creativity, a dedication to quality and best-in-class customer service.

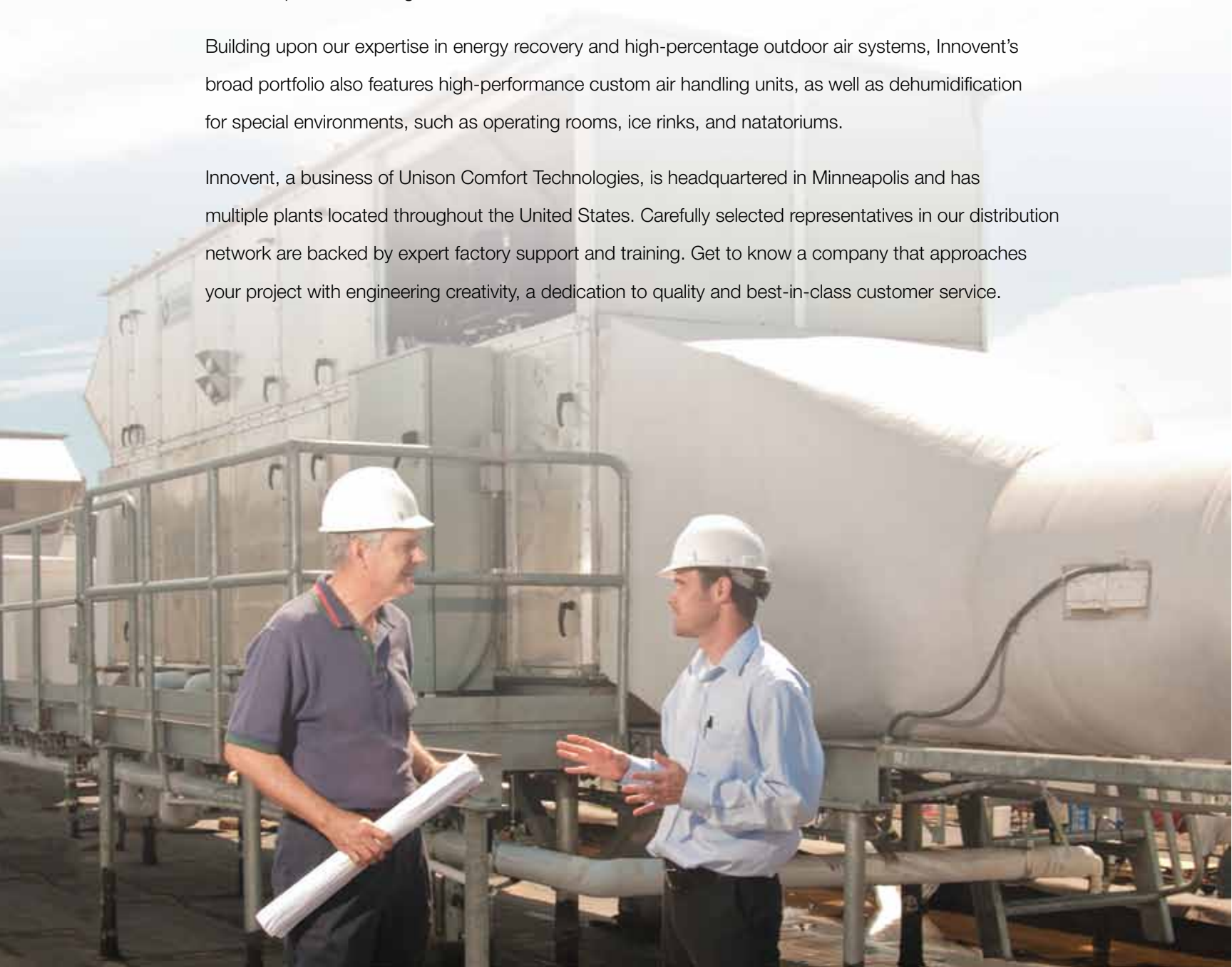

Engineering

specialized air handling products.



Innovent provides energy-efficient air handling solutions to meet critical performance, capacity and air-quality requirements. Our products deliver precise temperature and humidity control, assist in LEED accreditation and green building goals, and provide economical indoor air quality for buildings of all sizes and types. Our experts in high-efficiency refrigeration, dehumidification, control systems, heat transfer and energy recovery, work together to create today's most well-conceived, custom-designed air handling solutions.

- **CUSTOM AIR HANDLERS (C-SERIES)** — Large-scale, high-capacity systems custom engineered to deliver precision control in critical environments.
- **ENERGY RECOVERY (E-SERIES)** — Select from a wide array of energy recovery options to maximize energy transfer between separate air streams with tremendous design flexibility.
- **DESICCANT DEHUMIDIFICATION (D-SERIES)** — For low-humidity spaces controlled to tight tolerances, including surgical suites, ice rinks and archive storage.
- **POOL DEHUMIDIFICATION (P-SERIES)** — Deliver optimum amounts of fresh air, rather than recycled stale, indoor air, for a healthier, more comfortable swimming pool environment.
- **REPLACEMENT UNITS (R-SERIES)** — Direct replacement units are pre-designed to match existing footprints of major-manufacturers' catalogued units from the past in the 20-80 ton range. Get rid of unsightly, inefficient adapter curbs and upgrade performance using the Innovent replacement approach.



Multiple manufacturing facilities throughout the United States.

Designing

to meet exact requirements.

Design flexibility and creativity are applied to meet your unique needs, no matter how complex or challenging. Our engineers can design your unit using the standard or enhanced casing construction options noted below along with an extensive variety of internal components to address any space, application or quality concerns you may have.

1 Filtration Options

Pleated, cartridge, bag, HEPA, carbon and more.

2 Energy Recovery

Sensible or enthalpic plates, energy wheels, run-around coils or heat pipes. Innovent has the broadest spectrum of air-to-air energy recovery options available in the market. This allows us to review first cost, operating cost and operational concerns to select the most appropriate energy recovery method for a given project.



3 Controls Options

DDC controls with BACnet or Lonworks. Customized DDC controls can be provided on any Innovent unit, which allows for a fully functioning and factory-tested system prior to arrival at the job site.



Optional Perforated Inner Liner

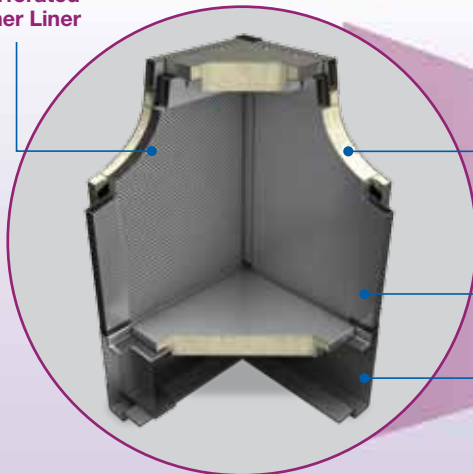

2" R12 Foam-Injected, Fully Removable, Thermal Break Panels (walls, ceiling and flooring)

Tube Frame

Fully-Welded Structural Steel Base

Standard Casing

Enhanced Casing Options

- 4" foam-injected walls
- All aluminum, stainless steel or coated inner and outer wall construction
- Fully-welded wash-down flooring
- Tread plate flooring
- Custom color-matched exterior
- And more!



4 Casing Construction Options

Custom casing aspect ratios allow us to build a unit of any size up to 200,000 cfm, customizing the arrangement in multiple ways to meet stringent design requirements. We can build units in multiple sections or completely "knocked-down" for the most difficult installations. Whether you need a horizontal airflow configuration, a completely vertical unit, or a combination of the two, our engineers can help. All Innovent units are designed with sufficient service access and a robust casing to help a properly maintained unit last well over 30 years.

5 Fan Options

Belt or direct drive, plenum or housed, fan arrays with or without sound reduction liners.



6 Heating Options

Indirect or direct fired gas, hot water, steam coils, IFB coils, electric heaters.



8 Packaged Refrigeration

For precise load matching, Innovent designs and builds customized refrigeration sections, from 5 to 400 tons, in air-cooled, water-cooled, heat pump and evaporative condenser arrangements. Whether cooling down to 40°F in a process application or only to 70°F in a data center environment, our custom refrigeration design approach can meet your exact needs using fixed speed, digital or variable speed scrolls; or screw compressors.



9 Serviceability

Full service access to all internal components requiring routine maintenance.



7 Cooling Options

Chilled water or DX coils, direct or indirect evaporative coolers.



10 Duct Connections

Can be provided in bottom, end, side or top locations.

Developing

custom air handling solutions.

CUSTOM AIR HANDLERS (C-SERIES)

Meeting unique challenges with cost-effective solutions has made Innovent an industry leader in the design of large, heavy-duty air handling systems for critical environments. Our engineers and sales representatives work closely with you to evaluate your specific heating, cooling and air-quality requirements and then custom design a one-of-a-kind, energy-efficient, dependable system to handle up to 200,000 cfm.

Options include 100-percent outside air, gas heating, evaporative cooling, chilled-water

and DX cooling, packaged refrigeration, electric heat, all-aluminum housings or other special casing construction, sectionalized equipment, “knock-down” field-assembled units, and direct-match replacement designs, including existing multizone units. Factory performance testing is available (casing leakage, panel deflection, airflow verification, basin leakage and sound verification) to ensure a premium quality unit is supplied and capable of delivering exactly what was specified.

C-SERIES

Custom Air Handlers (C-Series)

APPLICATIONS

- Hospitals
- Universities
- Labs
- Pharmaceutical
- Museums
- Data Centers
- Wastewater Treatment Plants



- Premium construction features such as 4" walls, fully welded wash-down floors, fan arrays, thermal break construction, and more.
- Stainless steel, aluminum or coated cabinet construction options.
- Capacities from 1,000 cfm to 200,000 cfm with up to 400-ton packaged refrigeration systems.

Supporting your sustainability efforts.

ENERGY RECOVERY UNITS (E-SERIES)

Innovent E-Series units recapture energy from air leaving the building and transfer it to fresh incoming air. Tempering incoming air through energy recovery minimizes operating costs by reducing equipment cooling and heating load requirements. These systems provide effective energy recovery in both heating and cooling seasons.

Innovent offers the industry's most diverse portfolio of energy recovery options, including ultra-efficient enthalpy wheels, sensible or enthalpic flat plate heat exchangers, heat pipe and run-around coils. Whether your design driver is lowest first cost, lowest operating cost, or lowest maintenance cost, Innovent has the right energy recovery solution for you.

Energy Recovery Units (E-Series)

APPLICATIONS

- **Dedicated Outdoor Air Systems (DOAS)**
- **Schools**
- **Casinos**
- **Labs**
- **Data Centers**
- **Industrial Processes**



- Multiple energy recovery options combined with flexible cabinet designs give HVAC designers the most flexible energy recovery products available in the industry.
- Units can include single or dual “wrap-around” energy recovery components to reduce the cooling load and provide free reheat, typically used in dedicated outside air systems.

E-SERIES



Controlling

humidity for health and comfort.

DESICCANT DEHUMIDIFICATION (D-SERIES)

Spaces that need to be maintained at low humidities and tight tolerances push typical air handling equipment beyond its capabilities. Innovent D-Series units deliver extra dry air to maintain spaces below 50% relative humidity, creating healthy and controlled environments for occupants in hospitals, clean rooms and research facilities. D-Series units also maintain controlled environments for preservation purposes such as museums, archive storage and ice rinks.

Our nonpatented approach provides design flexibility, allowing engineers to specify a non-proprietary system.

Available options include direct or indirect fired gas, hot water, or steam heating; chilled water or DX cooling; custom packaged refrigeration; and integrated, factory-wired DDC controls, designed and built in-house, with single-point wiring for easy installation.



D-SERIES

Desiccant Dehumidification (D-Series)

APPLICATIONS

- Ice Rinks
- Archive Storage
- Clinical & Surgical Rooms
- Industrial Processes



- Spaces can be maintained from 5% to 50% relative humidity using high temp, low temp or passive regeneration methods for reactivation of the desiccant wheel.
- Nonproprietary approach lets consulting engineers select the best system based on the specific space needs and keep the project within budget requirements.

Thriving

in aquatic environments.

POOL DEHUMIDIFICATION (P-SERIES)

Innovent's indoor swimming pool (natatorium) dehumidification units use outside air to control space humidity levels, maintain acceptable indoor air quality, minimize interior corrosion and reduce chloramine levels in the air. In the winter, dry outside air is used to create a fresh, comfortable environment, and reduce operating costs by eliminating the need for mechanical dehumidification. A 75-percent-efficient air-to-air heat exchanger drives costs even lower by capturing

heat from the exhaust air. In the summer, a DX or chilled-water coil chills outside air to keep pool humidity and temperature at controlled levels.

All Innovent P-Series units are designed to withstand the corrosive environment, using all-aluminum interior walls, an aluminum heat exchanger and coated heating coils. Since the Innovent unit requires no mechanical dehumidification for up to 80% of the year, it costs far less to operate than competitors' systems in most climatic zones.

Pool Dehumidification (P-Series)

APPLICATIONS

- Competition Pools
- Indoor Water Parks
- Recreational Centers
- Fitness Centers



- Supplies 20% - 50% fresh outdoor air for healthier occupants, lower operating costs, and minimized pool odors.
- Packaged air or water-cooled, split systems or chilled water coils; hot gas, hot water, steam, electric or gas furnace heating.
- Unlike competitors' systems, P-Series units are simple to install, operate and maintain.

P-SERIES

Upgrading

to higher efficiency and performance.

REPLACEMENT AIR HANDLERS (R-SERIES)

R-Series products are the smart way to replace aging, 20-80 ton air handlers with energy-efficient, direct-match units (using existing footprint and ductwork), avoiding extensive renovation costs. R-Series units reduce operating costs with direct-drive variable-speed fans, optional modulating compressors, modulating gas or electric heat, and customized refrigeration packages. DDC programmable controls are always included for improved scheduling and communications with existing building systems.



R-SERIES

Replacement Air Handlers (R-Series)

APPLICATIONS

- Office Buildings
- Shopping Centers
- Commercial Buildings

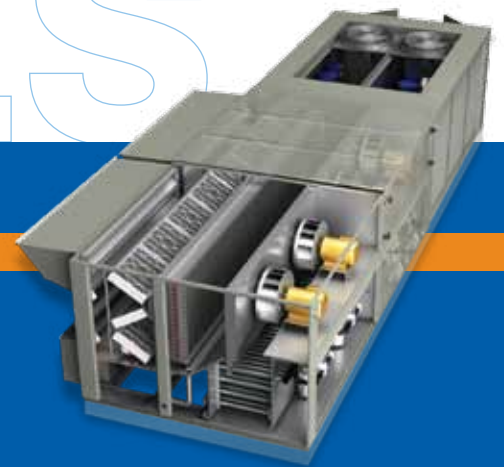

- Our direct-match replacement for existing Carrier D units is over 40% more efficient than the original model. Don't wait to replace; the right time is now.
- Innovent R-Series units match existing curbs, utility connections and duct connections, with the same or lower weight as the original model, all while upgrading performance.

Responding

to challenging HVAC needs
with industry-leading expertise.

Don't let catalogs limit your creativity!
With more than 30 years of custom
building experience, and 50+ degreed
staff engineers, Innovent can meet
your project needs. Contact your sales
representative and start the design of
your customized solution.



Innovent[®]
Air Handling Equipment

www.innoventair.com

Innovent

to help people
feel good inside.

For effective, energy-efficient and customized approaches to your air handling needs, work with the innovative team at Innovent. Our knowledgeable engineers, skilled assemblers and experienced field representatives share a common goal — your complete satisfaction.



Headquarters in Minneapolis, MN



Innovent
Air Handling Equipment

Bringing the outside in.

www.innoventair.com

For more information, contact your local representative or Innovent directly at:

60 28th Avenue North
Minneapolis, MN 55411
sales@innoventair.com

Phone 612.877.4800
Fax 612.877.4801